



Con Jagger Minotti risponde al desiderio di morbidezza e informalità. Una morbidezza variamente declinata, qualcosa che fa intuire tutto un mondo. Intanto si colga la dimensione puramente estetica: Jagger si dilata nello spazio senza scosse. La sua placida rotondità ha il sapore di un'accoglienza sobria, elegante e lussuosa. Ma poco sarebbe se il sistema non fosse capace di tradurre tanta intelligenza in un clima di informale modernità. Guardi Jagger e sai subito che parla un linguaggio contemporaneo, è facile dialogarci. Una volta seduto ascolti la certezza della tradizione, della cosa ben costruita. Sì, rock, ma un classico del rock. Fin'ora si è parlato al singolare, in realtà gli Jagger sono quattro. Variazioni dello stesso ceppo creativo firmato Rodolfo Dordoni. Variabili sono il bracciolo e lo schienale, nella loro espressione alta o bassa, o secondo l'intreccio delle due: "High Back", "High Back + High Armrest", "Low Back" e l'ultimo nato "Slim Armrest", il più adatto a spazi domestici contenuti, intimi. Queste declinazioni rendono possibile la scelta d'impulso, l'innamoramento condiviso. Vedi Jagger, sei sedotto dalla sua fresca morbidezza (addirittura, una fodera in piuma d'oca riveste i braccioli) e sai che esiste di sicuro il modello più adatto a te. Basta solo imparare a conoscerlo.

Struttura: in legno massello.

Preparazione della struttura: poliuretano espanso a quote differenziate ad alta densità. I braccioli sono rivestiti con trapuntino in piuma d'oca canalizzata che conferisce morbidezza e sofficià dando al bracciolo l'aspetto di un cuscino.

Cinghie: cinghie elastiche ad alta componente di caucciù e ad elasticità controllata.

Cuscinatura: cuscini schienale in piuma d'oca con poggiatesta integrato alla fodera del cuscino. Cuscini seduta reversibili realizzati in piuma d'oca canalizzata con inserto centrale in poliuretano espanso ad alta resilienza. Imbottitura della base realizzata con sede concava per accogliere il cuscino, favorendone la sofficià e la durata.

Piedino: in metallo Ø 25 mm con finitura cromata lucida e scivolanti protettivi in PVC.

Sfoderabilità: il rivestimento è completamente sfoderabile nella versione in tessuto, mentre è fisso nella versione in pelle.

Optional: cuscino Jagger 60x55 cm con imbottitura 100% in piuma d'oca canalizzata. Completamente sfoderabile.

Minotti relies on Jagger to answer the need for softness and casualness. Softness taking different shapes, something that makes you sense a whole world. Meanwhile let its purely aesthetic dimension be caught: Jagger expands in space, smoothly. Its calm roundness has the flavour of sober, smart, luxurious reception. However, this would be of no use, if the system were not able to translate such smartness into informal modernity. Just look at Jagger, and you will immediately know that it speaks a contemporary language, and that you can easily interact with it. Once seated, you will listen to the certainty of tradition, and well-built things. Yes, rock, but a classic of rock. So far we have spoken in the singular; yet there are four Jaggers, variations on the same creative stock, by Rodolfo Dordoni. Both the armrest and the back are changeable, either high or low or mixed: "High Back", "High Back + High Armrest", "Low Back" and the latest version, "Slim Armrest", which fits compact, intimate spaces best. These variations make impulsive choices and shared love possible. When you see Jagger, you are captivated by its fresh softness (the armrests are even padded with a goose down cover) and are aware that you can choose the model that suits you best, for sure. You just have to get to know it.

Frame: in solid wood.

Frame preparation: high density polyurethane foam of various densities. The armrests are covered with goose down quilts divided into sections, thus enhancing the softness of the upholstery and allowing the armrest to look like a cushion.

Straps: elastic straps with a high rubber content and controlled elasticity.

Cushions: backrests cushions made from goose down, complete with kidney rests built into the cushion covers. Reversible seat cushions made from goose down divided into sections with high resilience polyurethane foam inset. Hollow base designed to accommodate the cushion, resulting in enhanced softness and durability.

Feet: in metal Ø 25 mm bright chrome-plated finish with protective PVC glides.

Covers: fully removable in the fabric version, non-removable in the leather version.

Optional: Jagger cushion 60x55 cm padded with goose down divided into sections. Fully removable.

Mit Jagger kommt Minotti dem Wunsch nach weichen und informellen Möbeln nach. Inzwischen erfasst man die rein optische Dimension: Jagger weitet sich fließend im Raum aus, ohne anzustoßen. Seine ruhigen Rundungen heißen auf schlichte, elegante und luxuriöse Art Willkommen. Aber das hätte kaum Bedeutung, wenn das System nicht auch in der Lage wäre, all diese Intelligenz auf ein informell modernes Klima zu übertragen. Ein Blick auf Jagger genügt, um festzustellen, dass hier eine topaktuelle Sprache gesprochen wird, mit der man spontan ins Gespräch kommt. Im Sitzen spürt man dann die mit Traditionen einhergehende Sicherheit, die sich für eine gute Bauweise verbürgt. Ja, hier wird gerockt. Im Mittelpunkt steht jedoch ein Klassiker. Bis jetzt sprachen wir in der Einzahl. Tatsächlich gibt es aber vier Jagger. Variationen desselben kreativen Wurzelstammes, dessen Designer Rodolfo Dordoni ist. Arm- und Rückenlehne sind in der hohen und niedrigen Ausführung oder aber als Kombination beider Versionen erhältlich: "High Back", "High Back + High Armrest", "Low Back" und die neueste Kreation "Slim Armrest", die sich besonders in kleinere, intimere Räume gut einfügt. Diese Abweichungen ermöglichen eine impulsgesteuerte Auswahl, eine auf Gegenseitigkeit beruhende Verliebtheit. Beim ersten Blick besticht Jagger durch seine frische Weichheit (sogar die Armlehne ist mit einem Daunenbezug gepolstert) und vermittelt die Gewissheit, dass auch für jeden das richtige Modell dabei ist. Einzige Voraussetzung ist, dass man den richtigen Blickwinkel für Jagger entwickelt.

Rahmen: aus Massivholz.

Herstellung des Rahmens: Strukturaufbereitung aus hochelastischem Polyurethanschaum in unterschiedlicher Dichte. Die Armlehnen sind mit Gänsedaunen in Kammern bezogen, die weich und locker aufliegen und so der Armlehne das Aussehen eines Kissens verleihen.

Riemen: elastische Riemen mit hohem Kautschukanteil und kontrollierter Elastizität.

Kissen: die Rückenkissen bestehen vollständig aus Gänsedaunen und verfügen über eine in den Kissenbezug integrierte Nierenstütze. Die Sitzkissen sind wendbar und mit Gänsedaunen und einem mittigen Einsatz aus hoch widerstandsfähigem Polyurethanschaum gefüllt. Die Polsterung des Basisgestells verfügt über eine konkave Fläche, in der das Kissen sitzt. Dies begünstigt die Weichheit und Haltbarkeit.

Füße: glänzend verchromte Metallfüße, Ø 25 mm, mit Kunststoffgleitern.

Abnehmbare Bezüge: der Stoffbezug lässt sich komplett abnehmen, während der Lederbezug fix ist.

Optional: Kissen Jagger 60x55 cm mit Füllung aus 100% Gänsedaunen. Vollständig abziehbar.

Avec Jagger Minotti répond au désir de douceur et de spontanéité. Une douceur aux multiples déclinaisons qui laisse entrevoir tout un univers de possibilités. Découvrons tout d'abord la dimension purement esthétique de Jagger qui se dilate dans l'espace sans exagérations. Ses formes rondes et paisibles ont la saveur d'un accueil sobre, élégant et raffiné. Mais ceci serait bien peu de choses si le système n'était également capable de décliner toute cette finesse dans une ambiance à la fois moderne et informelle. Regardez Jagger et vous comprendrez tout de suite qu'il exprime un langage contemporain, ouvert au dialogue. Une fois assis, vous voici à l'écoute de la tradition la plus pure, des choses bien faites. Un style rock d'accord, mais un classique du rock. Si nous avons parlé jusqu'ici de Jagger au singulier, n'oublions pas qu'en réalité il existe quatre déclinaisons de la même inspiration créative griffée Rodolfo Dordoni. Les variables sont l'accoudoir et le dossier, en version haute ou basse, ou bien avec une combinaison des deux : "High Back", "High Back + High Armrest", "Low Back" et le dernier né de la série "Slim Armrest", le mieux adapté aux espaces domestiques petits et intimistes. Ces différentes déclinaisons vous permettront d'arrêter votre choix au premier regard, par un coup de foudre partagé. Vous voyez Jagger, vous êtes séduit par sa douce fraîcheur (d'autant qu'un garnissage en plumes d'oie recouvre les accoudoirs) et vous savez qu'il existe déjà le modèle qui est fait pour vous. Il ne vous reste plus qu'à apprendre à mieux le connaître.

Structure: en bois massif.

Préparation de la structure: polyuréthane expansé à hauteurs différenciées à haute densité. Les accoudoirs sont revêtus d'un matelassage en duvet d'oie à secteurs qui leur apporte souplesse et moelleux et leur donne l'aspect d'un coussin.

Sangles: sangles élastiques à haute teneur en caoutchouc et à élasticité contrôlée.

Coussins: les coussins du dossier sont réalisés en duvet d'oie avec appuie reins incorporé dans la housse du coussin. Les coussins de l'assise sont réversibles et réalisés en duvet d'oie à secteurs avec élément central en polyuréthane expansé à haute résilience. Rembourrage de la base réalisée avec un siège concave pour accueillir le coussin, tout en augmentant ainsi son moelleux et sa durée.

Pieds: en métal Ø 25 mm avec finition chromée polie et anti-glissements de protection en PVC.

Possibilité d'enlever la housse: revêtement en tissu entièrement déhoussable mais fixe dans la version en cuir.

Optionnel: coussin Jagger 60x55 cm avec rembourrage 100% duvet d'oie à secteurs. Entièrement déhoussable.

Minotti

JAGGER "HIGH BACK" (schienale alto - bracciolo largo cm 29 | high back - large armrest cm 29)

MODULO 85 CM (CUSCINO SEDUTA | SEAT CUSHION)

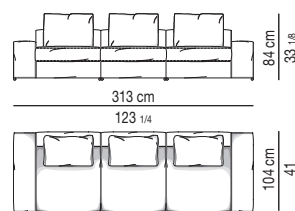
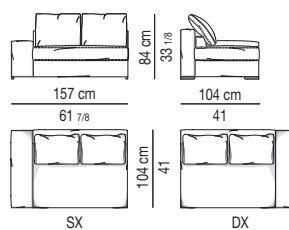
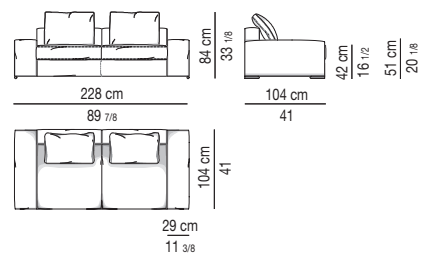

divano composto | three elements sofa

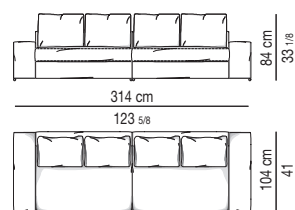
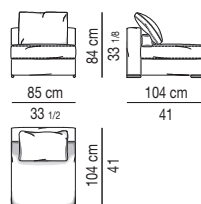

divano composto | two elements sofa

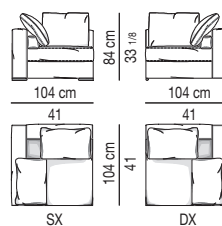
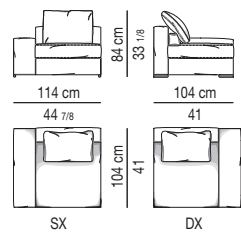
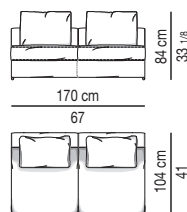

ELEMENTO ANGOLARE
CORNER ELEMENT

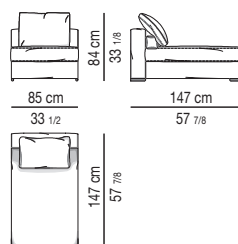
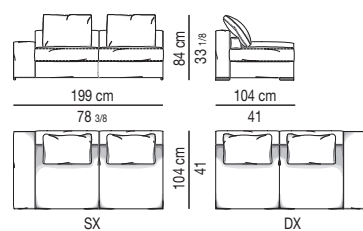

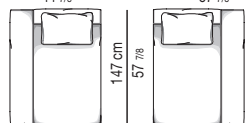
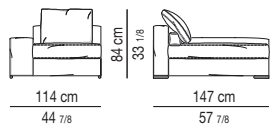
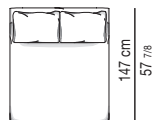
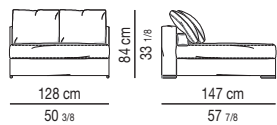

SX

DX

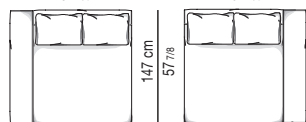
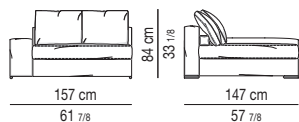

SX

DX

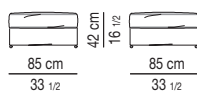
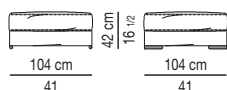

MODULO 75 CM (CUSCINO SEDUTA | SEAT CUSHION)

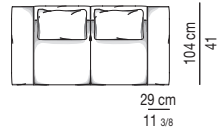
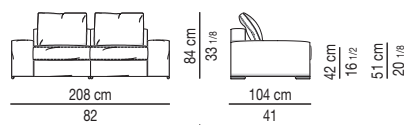

divano composto | two elements sofa

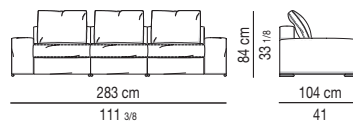

divano composto | three elements sofa

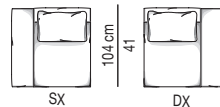
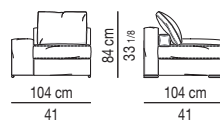

SX

DX

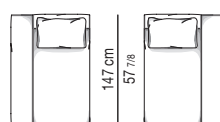
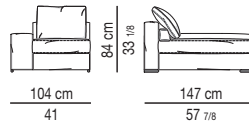
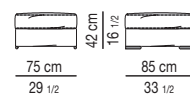
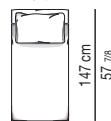
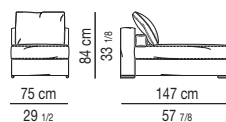
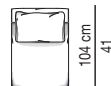
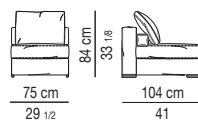

SX

DX

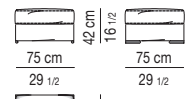

JAGGER "SLIM ARMREST"

(schienale alto - bracciolo stretto cm 21
high back - slim armrest cm 21)

MODULO 65 CM (CUSCINO SEDUTA | SEAT CUSHION)

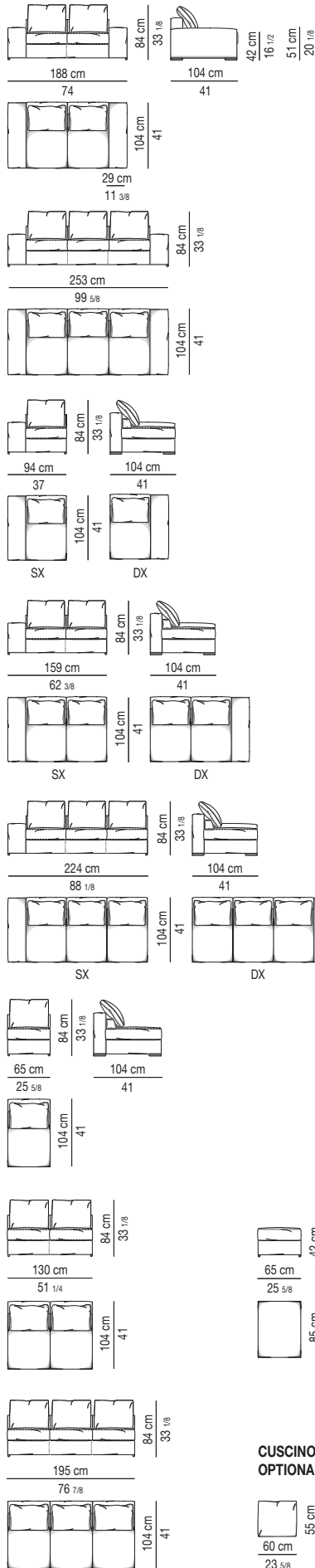

CUSCINO OPTIONAL
OPTIONAL CUSHION

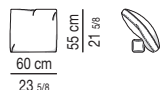

MODULO 85 CM (CUSCINO SEDUTA | SEAT CUSHION)

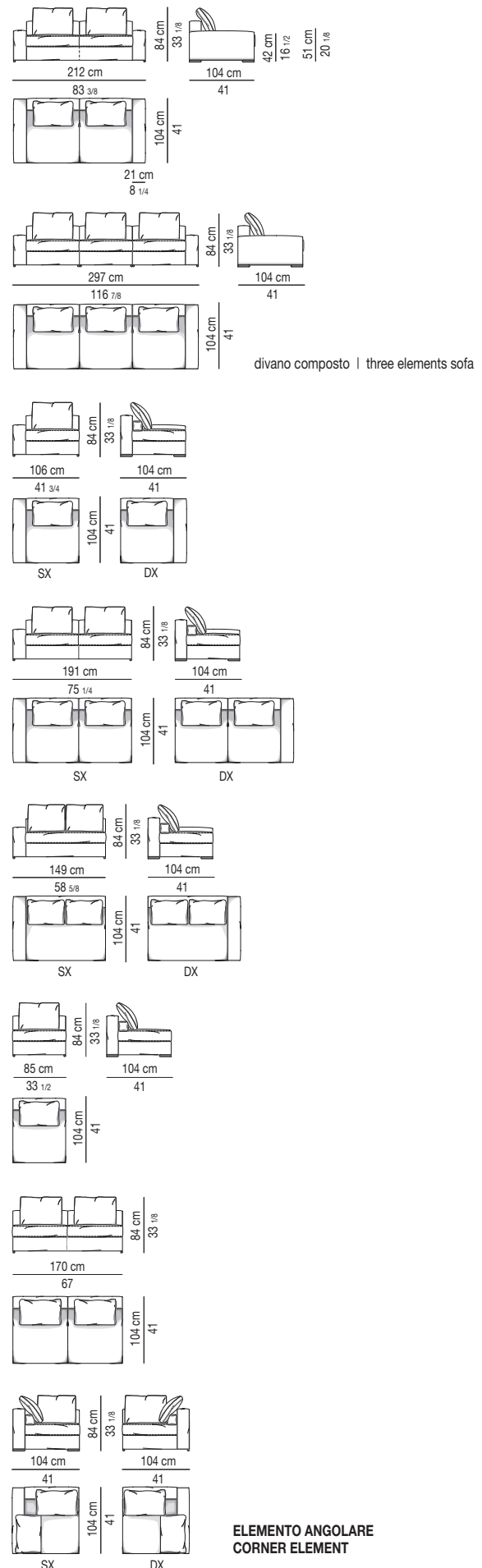

divano composto | three elements sofa

ELEMENTO ANGOLARE
CORNER ELEMENT

MODULO 65 CM (CUSCINO SEDUTA | SEAT CUSHION)

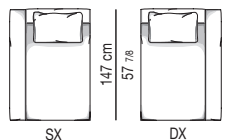
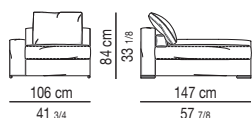

SX

DX

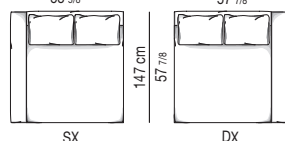
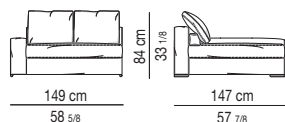

SX

DX

MODULO 75 CM (CUSCINO SEDUTA | SEAT CUSHION)

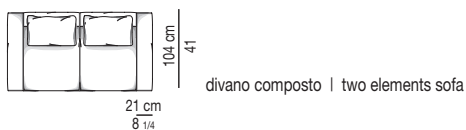
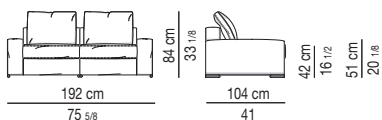

divano composto | two elements sofa

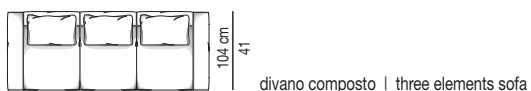
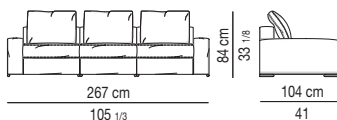

divano composto | three elements sofa

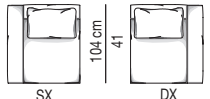
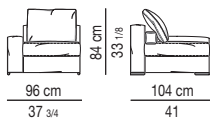

SX

DX

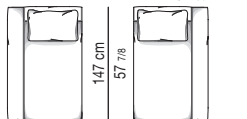
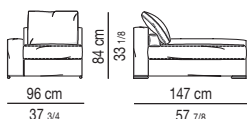
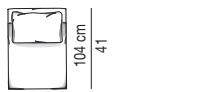
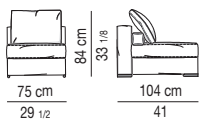

SX

DX

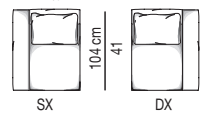
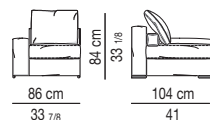
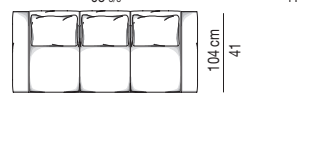
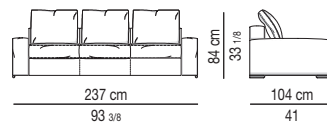
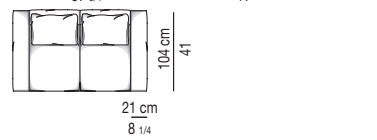
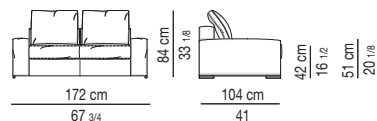

SX

DX

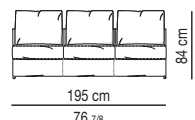
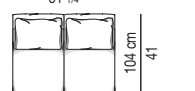
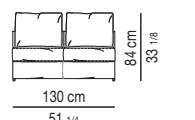
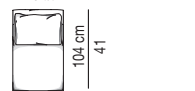
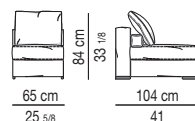

CUSCINO OPTIONAL | OPTIONAL CUSHION

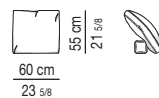

60 cm

23 5/8

Minotti

JAGGER "HIGH BACK + HIGH ARMREST"

(schienale alto - bracciolo alto cm 19 | high back - high armrest cm 19)

MODULO 85 CM (CUSCINO SEDUTA | SEAT CUSHION)

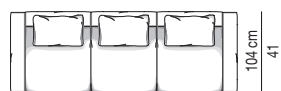
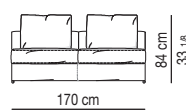
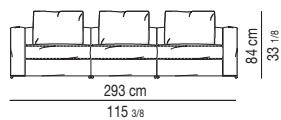
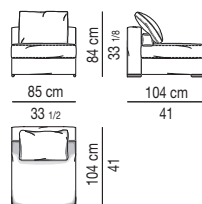
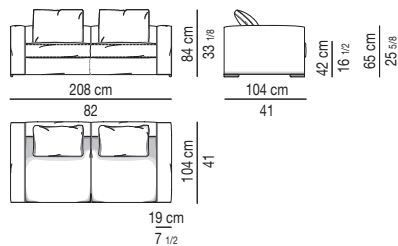

divano composto | three elements sofa

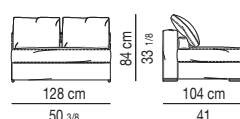
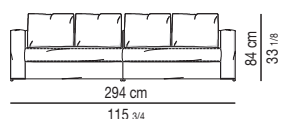
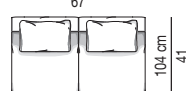

divano composto | two elements sofa

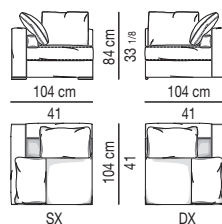
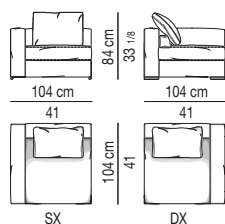
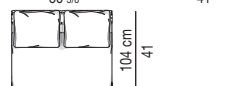

ELEMENTO ANGOLARE
CORNER ELEMENT

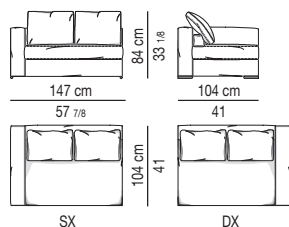
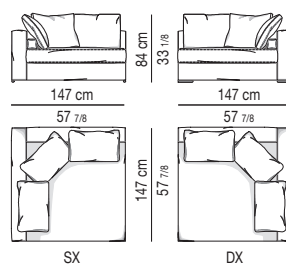
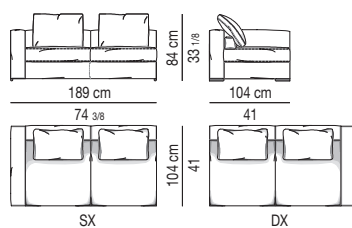

MODULO 75 CM (CUSCINO SEDUTA | SEAT CUSHION)

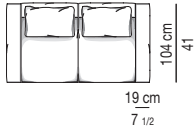
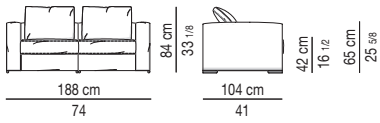

divano composto | two elements sofa

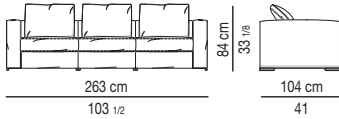

divano composto | three elements sofa

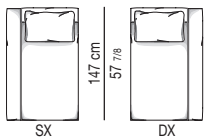
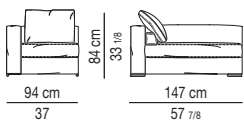
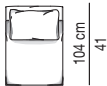
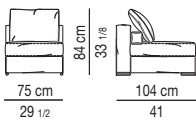
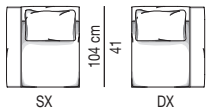
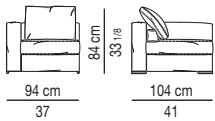

MODULO 65 CM (CUSCINO SEDUTA | SEAT CUSHION)

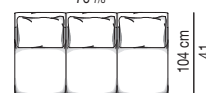
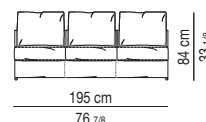
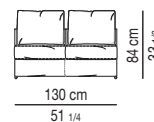
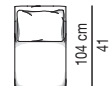
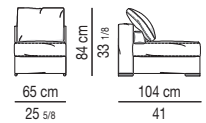
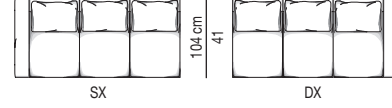
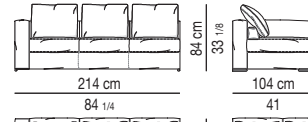
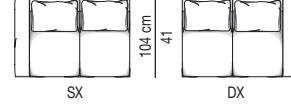
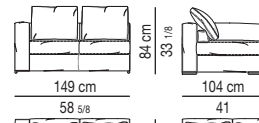
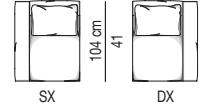
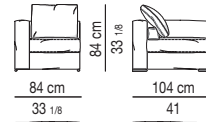
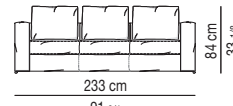
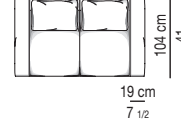
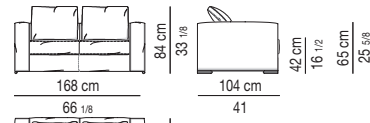

**CUSCINO OPTIONAL
OPTIONAL CUSHION**

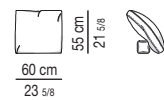

JAGGER "LOW BACK" (schienale basso - bracciolo basso cm 29 | low back - low armrest cm 29)

MODULO 85 CM (CUSCINO SEDUTA | SEAT CUSHION)

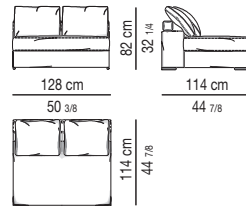
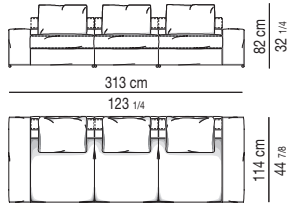
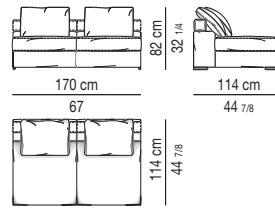
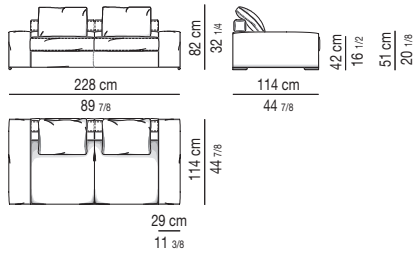

divano composto | three elements sofa

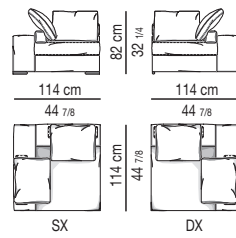
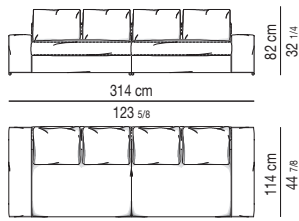

ELEMENTO ANGOLARE
CORNER ELEMENT

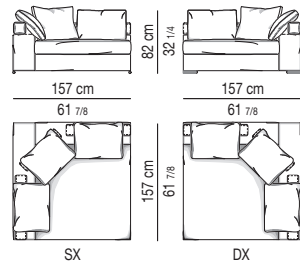
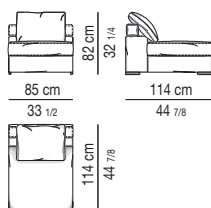
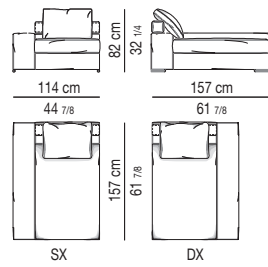
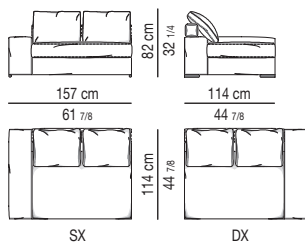
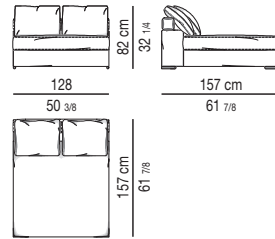
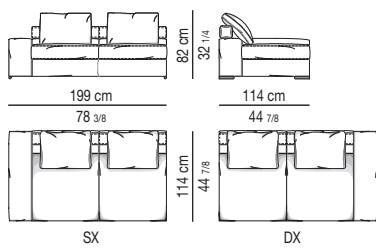
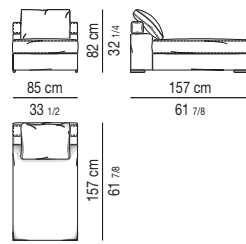
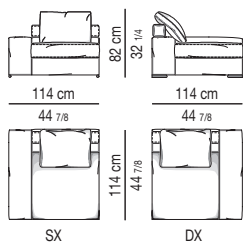

MODULO 65 CM (CUSCINO SEDUTA | SEAT CUSHION)

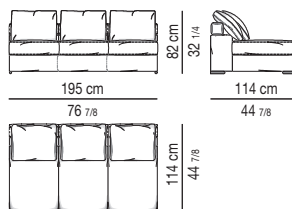
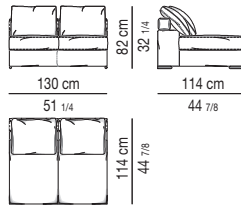
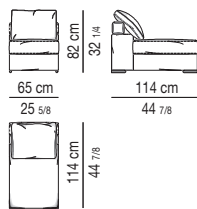
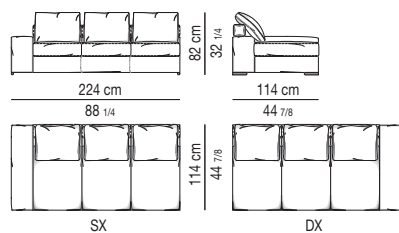
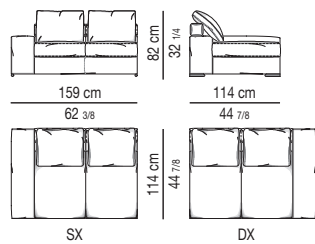
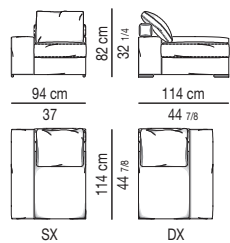
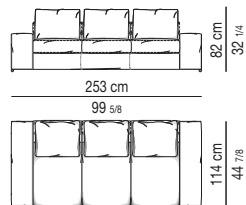
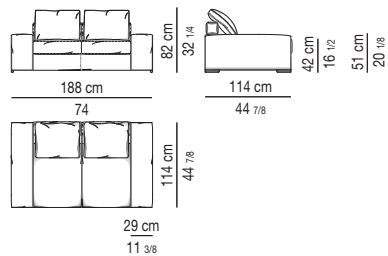

CUSCINO OPTIONAL | OPTIONAL CUSHION

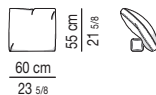

**ESEMPI DI MODI DIVERSI DI POSIZIONARE IL CUSCINO SCHIENALE
EXAMPLES OF HOW TO PLACE THE BACKREST CUSHION**

